



RB-SHERPA

INDOOR & OUTDOOR
LOGISTICS APPLICATIONS
DUE TO ITS
VERSATILITY & HIGH MOBILITY

INDUSTRIAL APPLICATIONS

AGRICULTURE

MILITARY

ORDER PREPARATION DELIVERY
PICKING & TRANSPORT



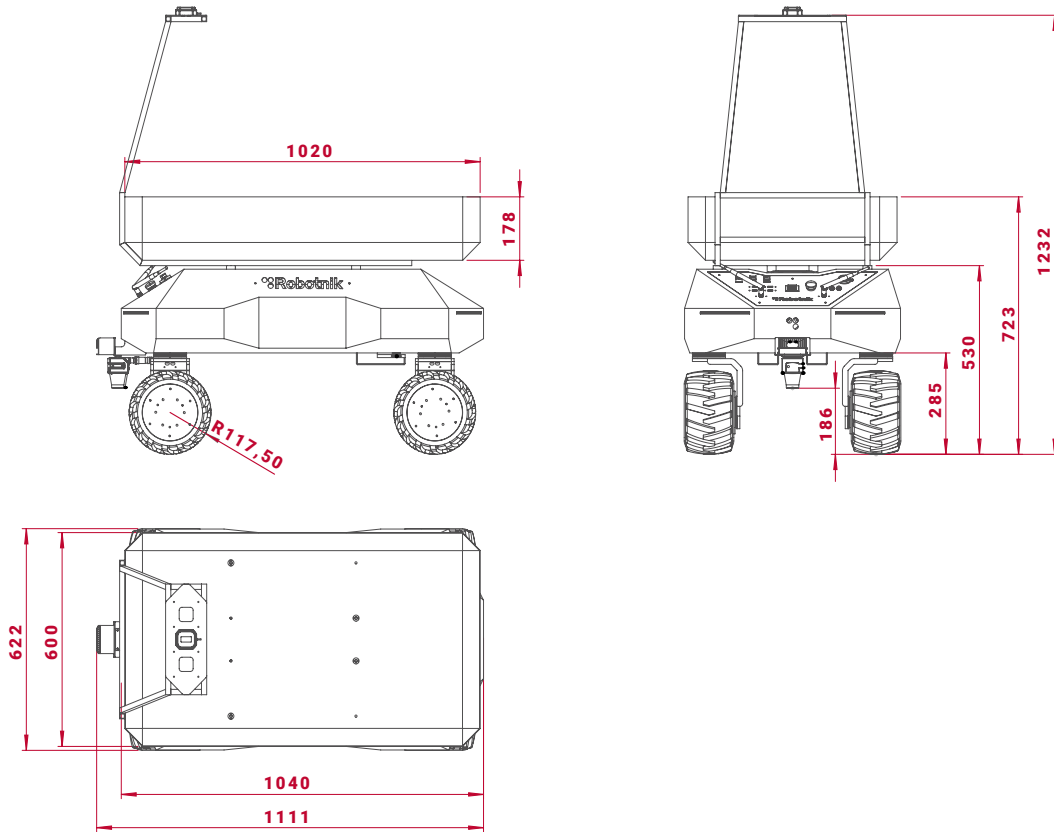

TECHNICAL SPECIFICATIONS

MECHANICAL

Dimensions	1.111 x 622 x 530/1.232 mm (Sensor frame)
Weight	165 Kg
Speed	2,5 m/s
Environment	Indoor / Outdoor
Autonomy	10 h continuous motion
Batteries	LiFePO₄ 30Ah@48V
Traction motors	4 x 500 W
Steering motors	2 x 100 W Ackermann 4 x 100 W OMNI 4
Temperature range	-10°C to +45°C
Payload	Up to 200 Kg
Max. Slope	25 %

CONTROL

Controller	Open architecture ROS Integrated PC with Linux
Communication	WiFi 802.11n
Connectivity	External: USB, RJ45, DC power supply