

RB-KAIROS

AUTONOMOUS MOBILE ROBOT (AMR)

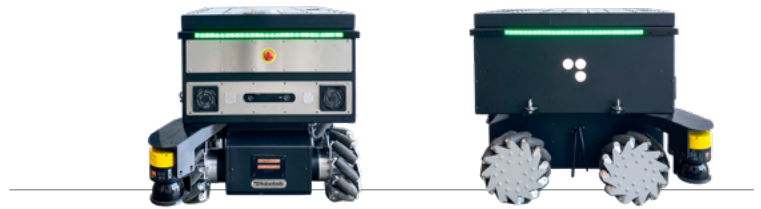

MOBILE PLATFORM READY TO
INTEGRATE A UR e-SERIES ARM
(UR3e/UR5e/UR10e/UR16e)

- PICK & PLACE
- METROLOGY
- PART FEEDING
- INDUSTRIAL APPLICATIONS
- R & D



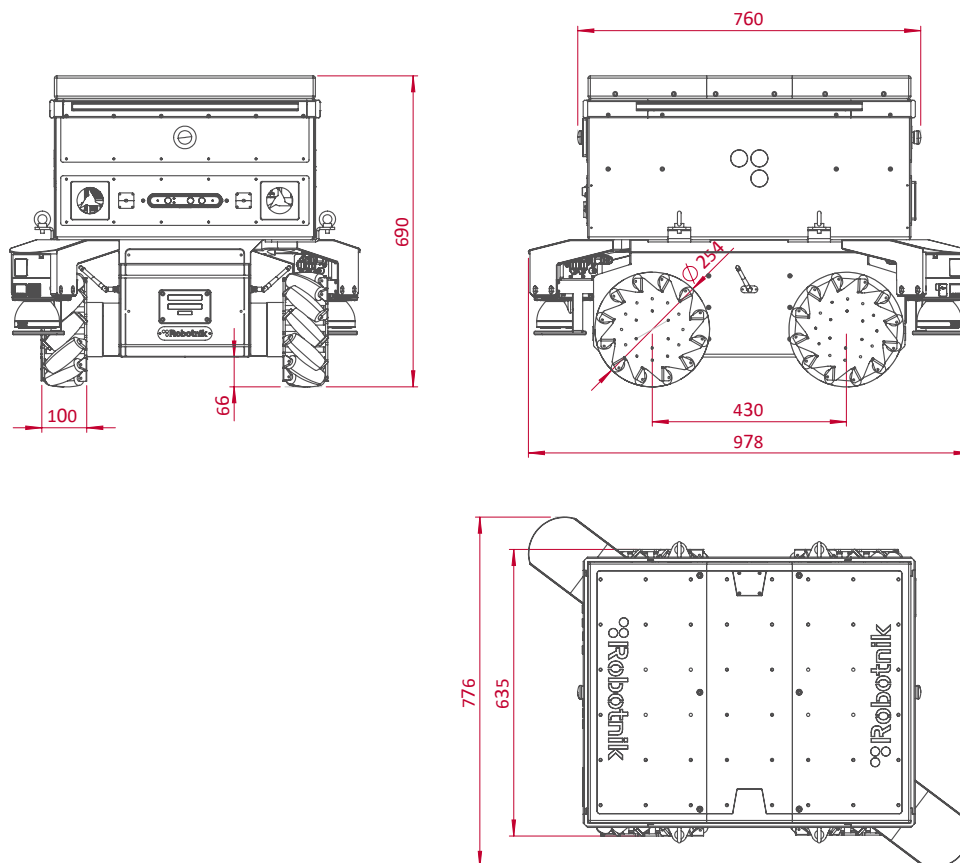

TECHNICAL SPECIFICATIONS

MECHANICAL

Dimensions **760 x 665 x 690 mm**

Weight **115 kg**

Payload **250 kg**

Speed **2 m / s**

Environment **Indoor**

Enclosure class **IIP54 / IP64**

Autonomy **6 / 12 h**

Batteries **LiFePO₄ 15 / 30Ah@48VDC**

Traction motors **4 x 500 W
Brushless servomotors with
safety brake**

Temperatura range **0° to +50°C**

Max. slope **10 %**

CONTROL

Controller **Open architecture ROS
Integrated PC with Linux**

Communication **WiFi 02.11a / b / g / n / ac
Bluetooth 5.1 (5G/4G optional)**

Connectivity **USB, RJ45, power supplies 12, 24
VDC and battery**

**Ready for plug and play
integration of Universal Robots™
arms (OEM DC Version)**