

# Servo Electric 2-Finger-Parallel Gripper Type PG 70 Assembly and Operating Manual



## Imprint:

### Copyright:

This manual remains the copyrighted property of SCHUNK GmbH & Co. KG. It is solely supplied to our customers and operators of our products and forms part of the unit. This documentation may not be duplicated or made accessible to third parties, in particular competitive companies, without our prior permission.

### Technical changes:

We reserve the right to make alterations for the purpose of technical improvement.

**Document number:** 0389273

**Edition:** 09.02 / 14.08.2012 / en

© SCHUNK GmbH & Co. KG, Lauffen/Neckar

All rights reserved

Dear Customer,

Congratulations on choosing a SCHUNK product. By choosing SCHUNK, you have opted for the highest precision, top quality and best service.

**You are going to increase the process reliability of your production and achieve best machining results – to the customer's complete satisfaction.**

**SCHUNK products are inspiring.**

Our detailed assembly and operation manual will support you.

Do you have further questions? You may contact us at any time – even after purchase..

Kindest Regards,

Your SCHUNK GmbH & Co. KG  
Precision Workholding Systems  
Bahnhofstr. 106 – 134  
D-74348 Lauffen/Neckar

Tel. +49-7133-103-2503  
Fax +49-7133-103-2189  
automation@de.schunk.com  
www.schunk.com



## Table of contents

<b>1</b>	<b>About this manual.....</b>	<b>5</b>
1.1	Purpose/validity.....	5
1.2	Target groups.....	5
1.3	Symbols in this manual .....	6
1.4	Terms used in this manual .....	6
<b>2</b>	<b>Basic safety notes .....</b>	<b>7</b>
2.1	Intended use .....	7
2.2	Environmental and operating conditions .....	7
2.3	Controlled production .....	8
2.3.1	Condition of the inputs/ outputs (I/O).....	8
2.3.2	Protective equipment.....	8
2.3.3	Constructional changes, attachments or modifications.....	8
2.3.4	Special standards .....	8
2.4	Personnel qualification .....	9
2.5	Safety-conscious working.....	9
2.6	Notes on particular risks.....	10
<b>3</b>	<b>Warranty .....</b>	<b>11</b>
<b>4</b>	<b>Scope of delivery .....</b>	<b>11</b>
<b>5</b>	<b>Accessories.....</b>	<b>12</b>
5.1	Connecting elements .....	12
5.2	Connection cap .....	13
<b>6</b>	<b>Technical Data .....</b>	<b>14</b>
6.1	Basic data .....	14
6.2	Factory settings / DEFAULT Value .....	14
6.3	Power supply requirements.....	15
<b>7</b>	<b>Description of the module.....</b>	<b>16</b>
7.1	Structure.....	16
7.2	Functional principle .....	17
7.3	Connection cap board .....	18
<b>8</b>	<b>Assembly and commissioning .....</b>	<b>19</b>
8.1	Mechanical Connection.....	19
8.2	Example of mounting .....	21
8.3	Electrical connection .....	21
8.3.1	EMV-fitting.....	22
8.3.2	RS232 interface.....	25
8.3.3	CAN interface .....	27

---

8.3.4	Interface Profibus DP .....	30
8.3.5	Electrical connection of the terminal strip X3 .....	32
8.3.6	DEFAULT and BOOT function.....	34
8.4	System integration .....	36
8.4.1	System structure.....	36
8.4.2	SCHUNK Motion protocol.....	36
8.4.3	Most important commands .....	37
<b>9</b>	<b>Troubleshooting.....</b>	<b>42</b>
9.1	Module does not move .....	42
9.2	The module is sluggish or jerky .....	42
9.3	The module's motor is not turning .....	42
9.4	Module stops abruptly .....	42
9.5	Motor turns but module does not move .....	43
9.6	The gripper does not execute the full stroke .....	43
9.7	The gripping force drops .....	43
9.8	The gripper opens or closes abruptly .....	43
<b>10</b>	<b>Maintenance and care .....</b>	<b>44</b>
10.1	Maintenance intervals .....	44
10.2	Lubricants/Lubrication points (basic lubrication).....	44
10.3	Dismantling the module.....	45
<b>11</b>	<b>Translation of original EC declaration of incorporation.....</b>	<b>47</b>

## Applicable documents (on CD-ROM)

- SCHUNK Catalog **Gripping Modules**
- Assembly and Operating Manuals for sensors
- General terms of business (AGB)

The specified data can alternative downloaded on the following page: [www.schunk.com](http://www.schunk.com).

# 1 About this manual

## 1.1 Purpose/validity

This manual is part of the module and describes the safe and proper use during all phases of operation.

This manual is valid only for the module specified on the front page.

## 1.2 Target groups

Target group	Task
Manufacturer, operator	<ul style="list-style-type: none"><li>➔ Keep this manual available for the personnel at all times.</li><li>➔ Require personnel to read and observe this manual and the applicable documents, especially the safety notes and warnings.</li></ul>
Skilled personnel, fitter	<ul style="list-style-type: none"><li>➔ Read, observe and follow this manual and the applicable documents, especially the safety notes and warnings.</li></ul>

Table 1

### 1.3 Symbols in this manual

To give you quick access to information, the following symbols will be used in this guide:





Symbol	Designation
 <b>DANGER</b>	Dangers for persons. Nonobservance causes death or serious injuries.
 <b>WARNING</b>	Dangers for persons. Nonobservance can cause death or serious injuries.
 <b>NOTICE</b>	Information on avoiding material damage, for explanation or to optimize the work processes.
✓	Prerequisite for a handling .
➔	Handling instruction, also measures in a warning or .
1. 2. 3. ...	Step-by-step handling instruction. ➔ Observe the order.
	Component/spare part represented in a graphic.
	Part/detail shown in a graphic which is part of a spare part or which must be provided by the customer.
(10), (/10/)	Reference in the text or in a handling instruction to a part that is represented in a graphic.
Master M ⇔ Slave S	Parameter will be transferred from Master M to Slave S

Table 2

### 1.4 Terms used in this manual

Term	Meaning
Cycle	A cycle includes the following movement: ➔ to open and close the gripper once

Table 3

## **2 Basic safety notes**

### **2.1 Intended use**

The module was designed to grip and to temporarily and reliably hold workpieces or objects.

The module is intended for installation in a machine. The requirements of the applicable guidelines must be observed and complied with.

The module may be used only in the context of its defined application parameters.

Any other use or use exceeding that specified is an infringement of use for intended purpose. The manufacturer bears no liability for damage resulting from such use.

### **2.2 Environmental and operating conditions**

- ➔ The module may be used only in the context of its defined application parameters (see chapter 6, page 14 and catalog).
- ➔ Make sure that the module and the top jaws are a sufficient size for the application.
- ➔ Make sure that the environment is clean and the ambient temperature corresponds to the specifications per the catalog. Maintenance and lubrication intervals, (see chapter 10.1, page 44)
- ➔ Make sure that the environment is free from splash water and vapors as well as from abrasion or processing dust. Excepted are modules that are designed specially for contaminated environments.

## 2.3 Controlled production

The module represents the state of the art and the recognized safety rules at the time of delivery. However, it can present risks if, for example:

- The module is not used in accordance with its intended purpose.
- The module is not installed or maintained properly.
- The EC Machinery Directive, the VDE directives, the safety and accident-prevention regulations valid at the usage site, or the safety and installation notes are not observed.

### 2.3.1 Condition of the inputs/ outputs (I/O)

During the run-up of the module, and due to the peculiarities of the used processor, not defined I/O conditions may occur.

➔ Do not allow a direct connection with actuators.

### 2.3.2 Protective equipment

➔ Provide protective equipment per EC Machinery Directive.

### 2.3.3 Constructional changes, attachments or modifications

Additional drill holes, threads, or attachments that are not offered as accessories by SCHUNK may be attached only with permission of SCHUNK.

### 2.3.4 Special standards

The following harmonized standards were adhered to:

- Fast transient events on supply lines and I/O lines (burst) according to IEC/ EN 61000-4-4
- HF power input according to IEC/EN 61000-4-6
- HF irradiation according to IEC/ EN 61000-4-3
- Interference field strength in the 3m absorber chamber according to German version EN 55011:2007 +A2 class A (corresponds to EN 61000-6-4:2007)



## **2.4 Personnel qualification**

The assembly, initial commissioning, maintenance, and repair of the module may be performed only by trained specialist personnel.

The assembly, initial commissioning, maintenance, and repair of the module may be performed only by trained specialist personnel.

Every person called upon by the operator to work on the module must have read and understood the complete Assembly and Operating Manual, especially chapter 2 "Basic safety notes". This applies particularly to occasional personnel such as maintenance personnel.

## **2.5 Safety-conscious working**

- ➔ Avoid any manner of working that may interfere with the function and operational safety of the module.
- ➔ Observe the safety and accident-prevention regulations valid at the usage site.

## 2.6 Notes on particular risks

### **Risk of injury from objects falling and being ejected!**

- ➔ Provide protective equipment to prevent objects from falling or being ejected, such as processed workpieces, tools, chips, fragments, rejects.

### **Risk of injury when the machine/system moves unexpectedly!**

- ➔ Do not move parts by hand when the energy supply is connected.
- ➔ Do not reach into the open mechanism or the movement area of the module.
- ➔ Remove the energy supplies before installation, modification, maintenance, or adjustment work.
- ➔ Perform maintenance, modifications, and additions outside the danger zone.
- ➔ For all work, secure the module against accidental operation.

### **3 Warranty**

The warranty is valid for 24 months from the delivery date to the production facility under the following conditions:

- Intended use in 1-shift operation
- Observation of the maintenance and lubrication intervals (see chapter 10.1, page 44)
- Observation of the ambient conditions and operating conditions (see chapter 2.2, page 7)

Parts touching the workpiece are not part of the warranty. Also observe our general terms of business.

### **4 Scope of delivery**

The scope of delivery includes:

- Servo Electric 2-Finger-Parallel Gripper PG in the version ordered
- USB to RS232 converter inclusive driver CD
- DVD

Content of DVD:

- Motion Tool Schunk (MTS is a configuration and commissioning tool)
- Operating manual in PDF format
- MotionControl software manual in PDF format

#### **Note**

The module is delivered without connection cap ASK. It can be ordered separately as accessory.

Connection cap ASK is necessary for operation.

The following accessories are available for the module:

- connecting elements (PAM)
- Cable (Feldbus and power supply)
- Connection cables
- Order accessories separately.
- For additional accessories, see catalog.

**Notes**

Older versions require the PowerConfig tool from the DVD for flashing. If older versions are to be used, contact your SCHUNK representative.

**5 Accessories****5.1 Connecting elements**

→ See catalog for exact type designations of compatible connecting elements.

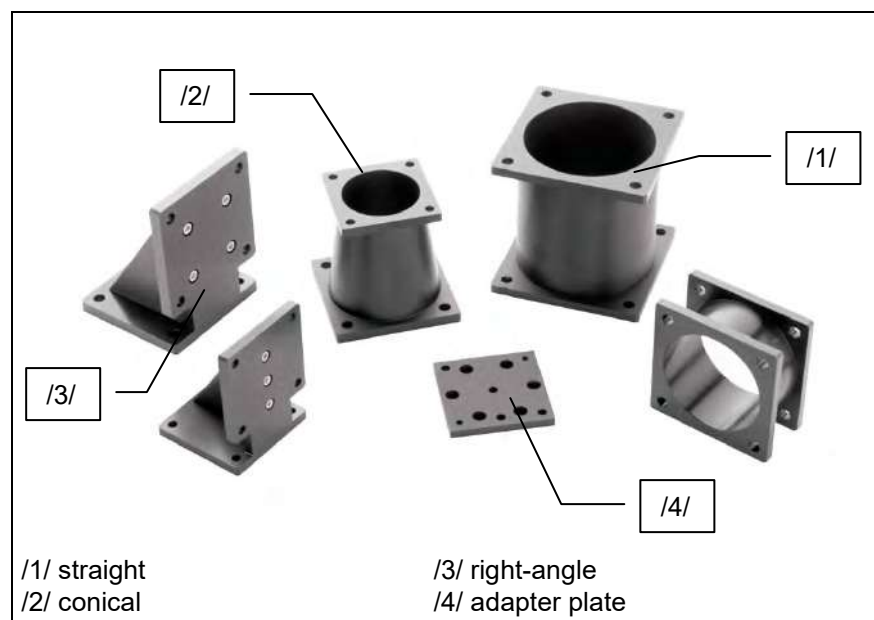

Figure 1

## 5.2 Connection cap

→ See catalog for exact type designations of connection cap.



Figure 2

Item	Designation
/1/	DMI
/2/	DMI with Bluetooth
/3/	MMI

Table 4 Legend to Figure 3

## 6 Technical Data

### 6.1 Basic data

Further technical data can be found in our catalog The most recent version applies.

		<b>Type</b>	<b>70</b>
<b>Mechanical operating data</b>		weight [kg]	1.4
		noise level [dB(A)]	≤ 70
		IP rating (when using DMI-connection cap)	20
		ambient temperature [°C]	
		Min.	+5
		Max.	+55
<b>Electrical operating data</b>		Min. / Max. gripping force [N]	30 / 200
		Stroke per finger [mm]	34
		power supply [V DC]	24
		nominal power current [A]	1.4
		max. current [A]	1.8
<b>integrated electronics</b>		Interface	
		RS232	X
		CAN	X
		Profibus DP	X
		power supply [V DC]	24
		nominal power current [A]	0.5
	sensor system	Encoder	

Table 5

### 6.2 Factory settings / DEFAULT Value

<b>Reference</b>	<b>DEFAULT</b>
Interface	RS232
Data rate	9600
Module address	12

Table 6

### 6.3 Power supply requirements

Designation	Value
Output power supply (motor)	PG 70
	24 V DC
Power supply for logic	24 V DC +10% / -4%; Residual ripple < 150mVSS; Switching peak < 240mVSS
Connection value	Number of modules x Rated module cur-

Table 7

#### Notes:

If the module is actuated at high values of speed, acceleration and jerk while it is moving into position, voltage peaks can occur due to an energy recovery of the drive during the deceleration/slow down phase.

The terminal voltage of the power supply can increase beyond the output voltage of the power supply.

The used power supply unit has to withstand this overvoltage, and should not switch off its output voltage.

Otherwise the module will stop with the error message "ERROR\_Motor\_Voltage\_LOW!", which has to be confirmed.

Therefore we recommend that the module will be connected as follows:

1. Connection of the power supply (logic) of the module to the SPS power supply (e.g. Sitop)
2. Connection of the module's power supply to a transformer power supply or to a switching power supply (e.g. Murr switching power supply MCS20-230/24 Art.-No. 85087)

The GND connections of both power supplies have to be connected with each other.

## 7 Description of the module

### 7.1 Structure

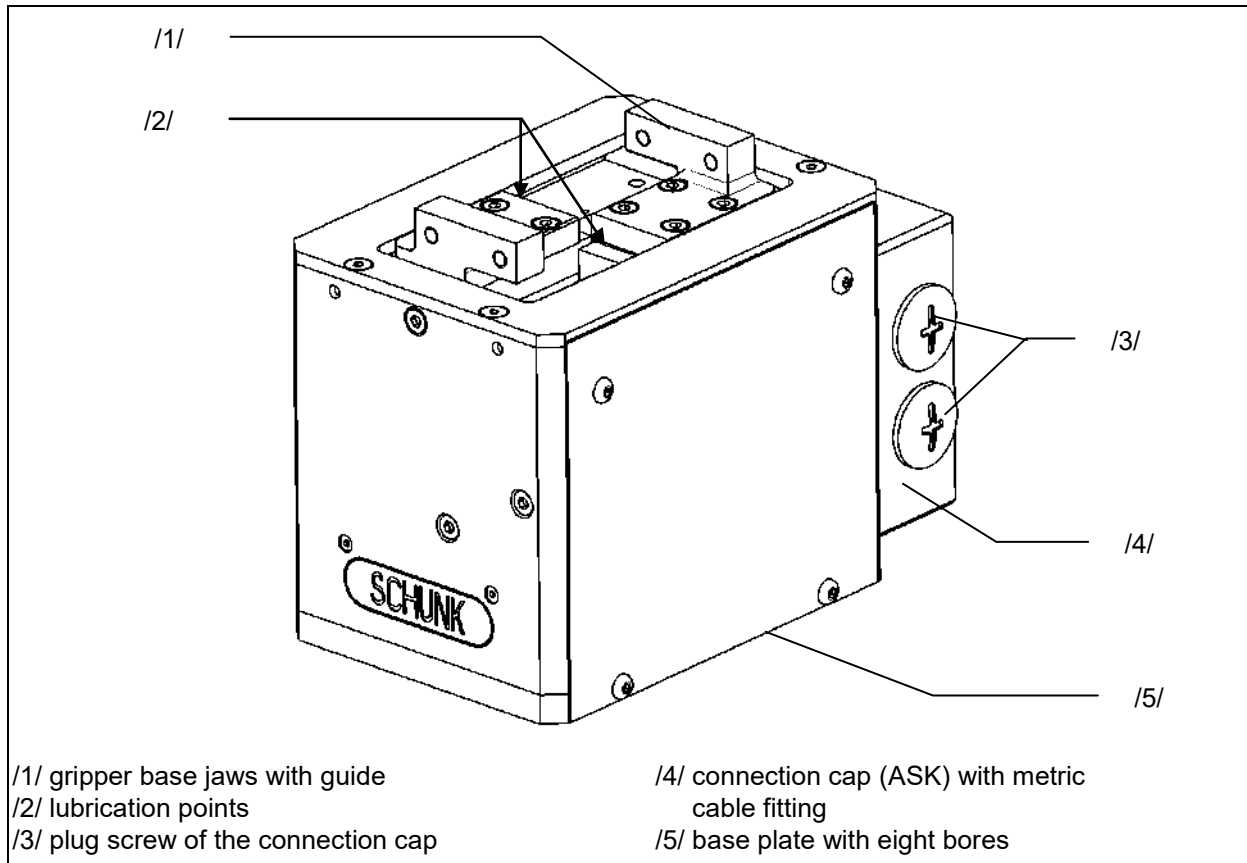

Figure 4



## 7.2 Functional principle

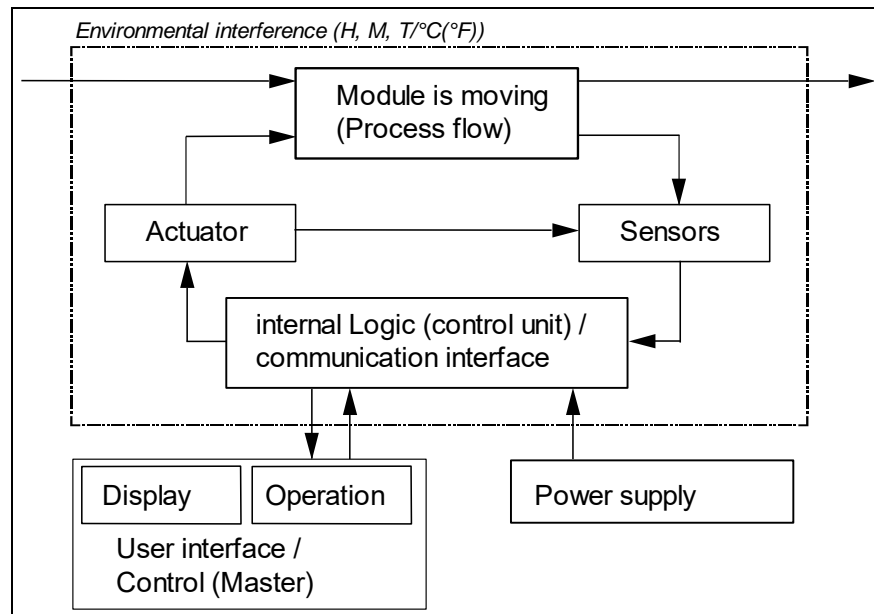

Figure 5

The actuator (in this case a DC motor per axis) is controlled by the internal logic. The required parameters are transferred from the higher level controller (master) to the internal logic.

The following parameters can be transferred from the controller (master) to the internal logic:

- Current  $I$ ;
- Velocity  $v$ ;
- Acceleration  $a$
- Position

### Notes

All possible parameters and the relevant features of the individual bus systems are described in more detail in the document about the SCHUNK Motion protocol (see DVD, document: MotionControl.pdf).

### 7.3 Connection cap board

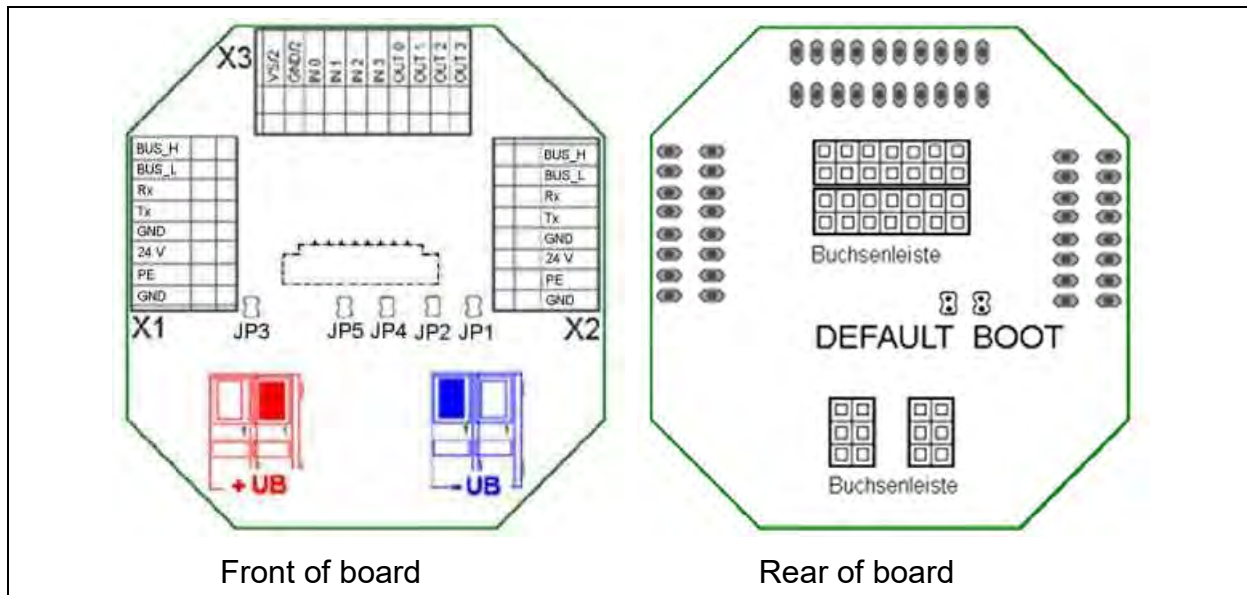

Figure 6

- On the front of the board (connection side) are the connecting terminals X1, X2 and X3. The individual jumper connectors (JP1-JP5) for each interface and the motor output (+UB, -UB) are also located here.
- Function of terminals:
- X1 is the main connecting terminal for the module's communication
- X2 is for the links to other modules
- X3 is for the use of digital inputs and outputs. Additional sensors can be connected here. The assignment of this terminal is independent of the interfaces (see chapter 8.3.5, page 32)

On the rear of the board (plug-in side to module) are the socket strips and the jumper connectors for the "BOOT" and "DEFAULT" functions (see chapter 8.3.6, page 34).

## 8 Assembly and commissioning

### 8.1 Mechanical Connection

**⚠ WARNING**

**Risk of injury when the machine/system moves unexpectedly!**

➔ Switch off energy supply.

**Check the evenness of the bolting surface**

The values relate to the entire bolting surface.

Edge length [mm]	Permissible unevenness [mm]
< 100	< 0,02
> 100	< 0,05

*Table 8 Requirements for levelness of the bolting surface*

- ✓ The installation position of the module has been designed so that cable wrapping is not possible.
- ➔ Use suitable connecting elements (adapter plate) to connect the module in the machine / system.
- ➔ Observe the permissible length of engagement.
- ➔ Observe the tightening torque of the screws (see Figure 7, page 20)

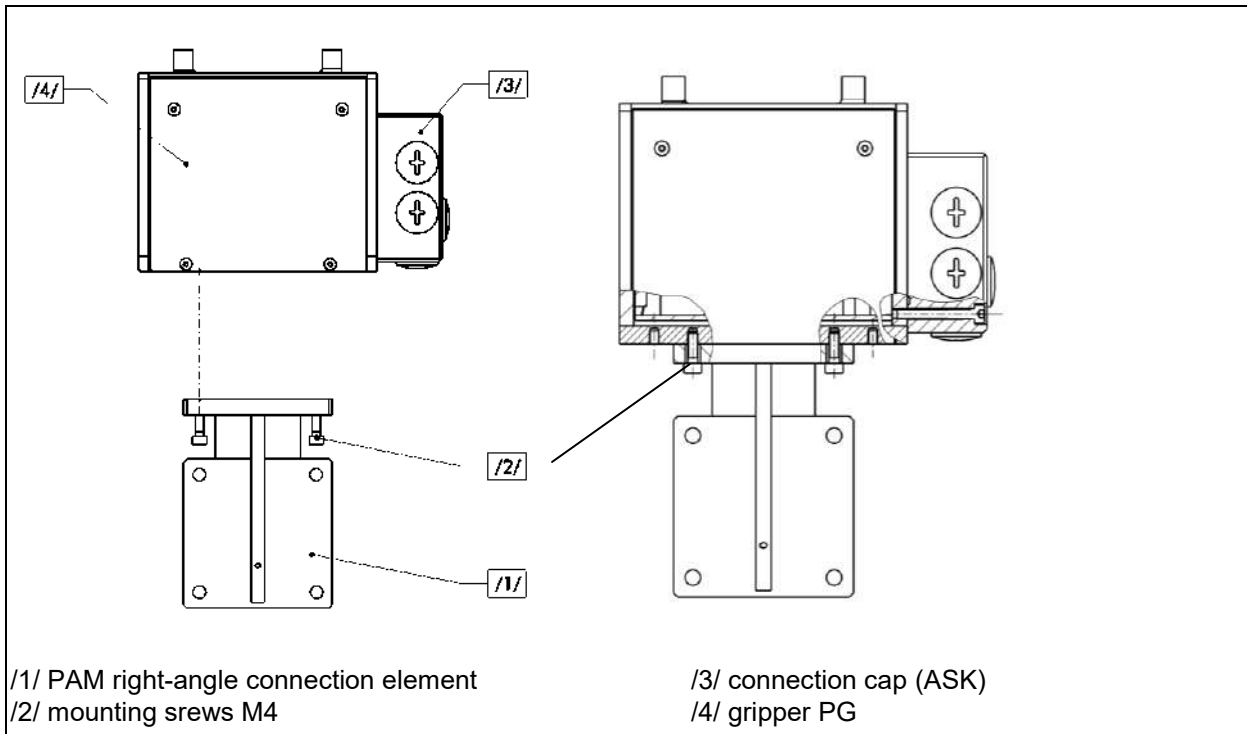

Figure 7 Mounting of the module with PAM right-angle connection element

The customer must provide the following mounting material:

Item	Designation	Note
1/1	Connection element	See catalog (accessories, PAM)
1/2	screws	4 pieces for each side of the connection element

Table 9 Befestigungsmaterial

	PG 70
thread	M4
Minimum of engagement [mm]	5
tightening torque [Nm]	3
The data refers on screws of the strenght class 8.8	

Table 10

## 8.2 Example of mounting

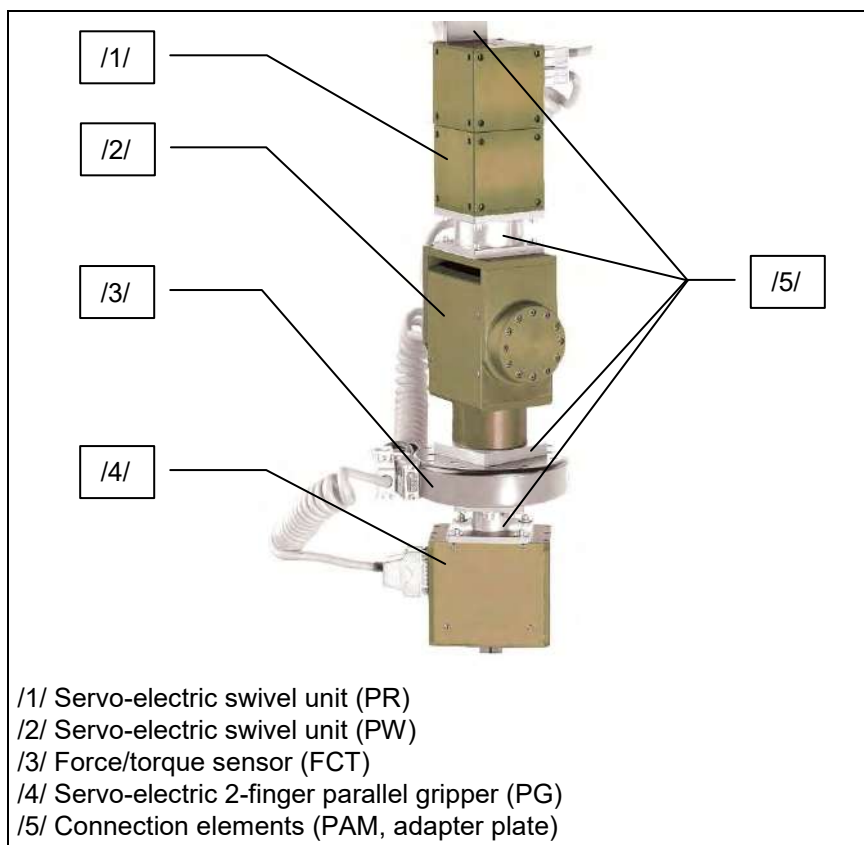

Figure 8

## 8.3 Electrical connection

### Notes

The cable color throughout this chapter relates to the use of a SCHUNK connecting cable.

8.3.1 EMV-fitting

**⚠ WARNING**

**Risk of injury when the machine/system moves unexpectedly!**

➔ Switch off energy supply.

**! NOTICE**

**Damage to board if screws are too tight!**

➔ Only fix the screws in place on the board.

**Notes**

Observe the maximum electrical energy values (see chapter 6, page 14).

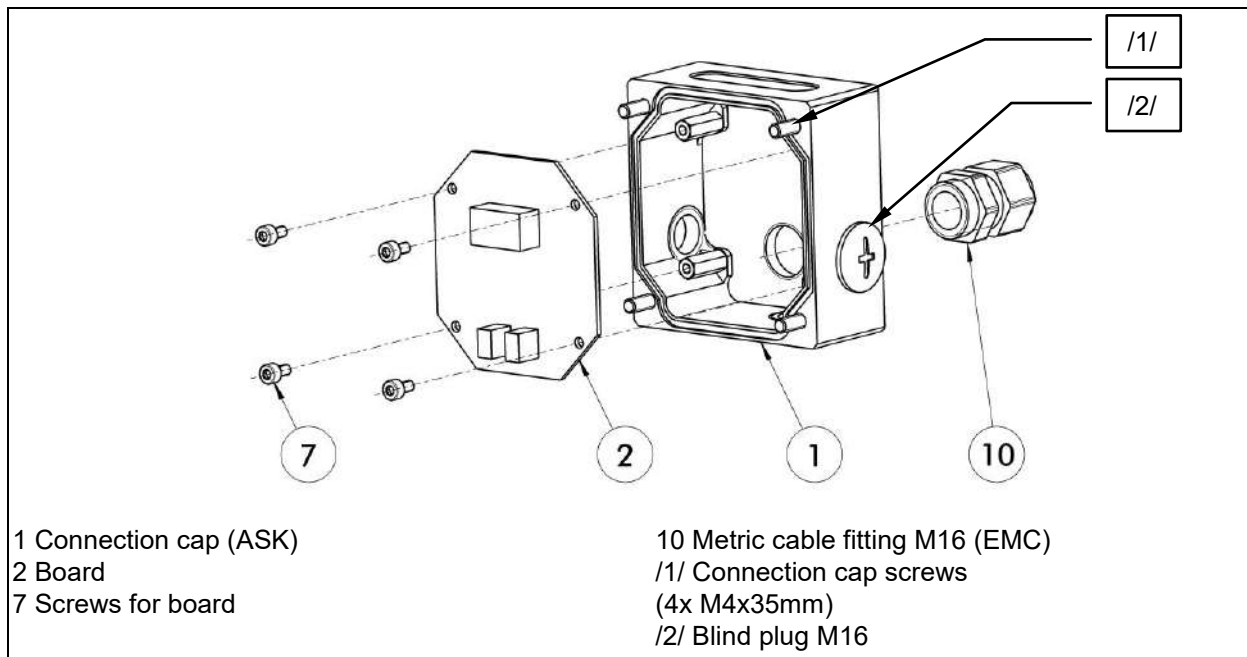

Figure 9

- ✓ The module is delivered without connection cap ASK. It can be ordered separately as accessory. Connection cap ASK is necessary for operation.

(for item, see Figure 9, page 22)

1. Loosen the screws (/1/) for the connection cap (1) with a hexagon socket wrench (size 3).
2. Detach the connection cap (1) from the module.
3. Carefully unscrew the screws (7) for the board (2) with a hexagon socket wrench (size 2.5).
4. Carefully remove the board (2) from the connection cap (1) and place it safely to one side.
5. Unscrew the blind plug (/2/) to achieve an optimum connecting cable position.
6. Pull the connecting cable through the metric cable fitting (10).
7. Strip approximately 50mm from the connecting cable.
8. Strip around 5 mm of the individual wires, sufficient for the terminals.
9. Push the outer connecting cable shielding back over the cable sheath.
10. Fix the shielding in place with shrink hose in such a way that the shielding remains visible at the end of the sheath (see Figure 10, page 24).
11. Pull the connecting cable through the connection cap (1) and connect the board (2) according to the required interface (see chapter 8.3.2, page 25).
12. Pull the metric cable fitting (10) over the shrink hose so that the individual wires are still visible.  
(see Figure 10, page 24).
13. Screw metric cable fitting (10) onto connection cap (1).
14. Carefully slide the board (2) back into the connection cap (1).
15. Carefully tighten the screws (7) on the board (2).

16. Replace the connection cap (1) on the module and tighten the screws (/1/) to a maximum of 3 Nm.

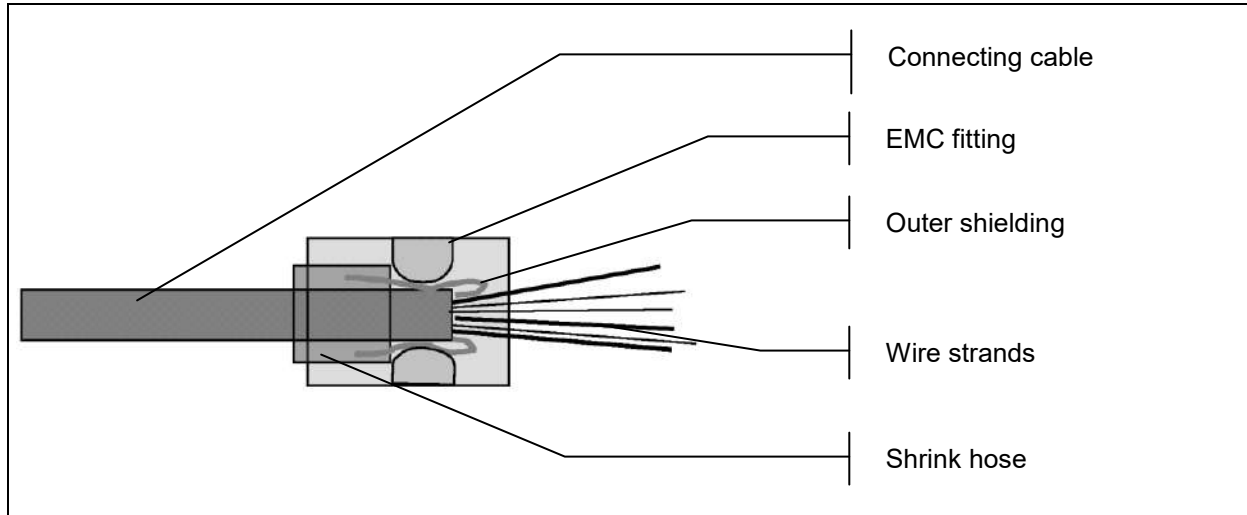

Figure 10 EMC fitting



### 8.3.2 RS232 interface

The communication interface RS232 can't be used as a field bus because of its properties.

→ The RS232 interface should be only used as a parameterization interface.

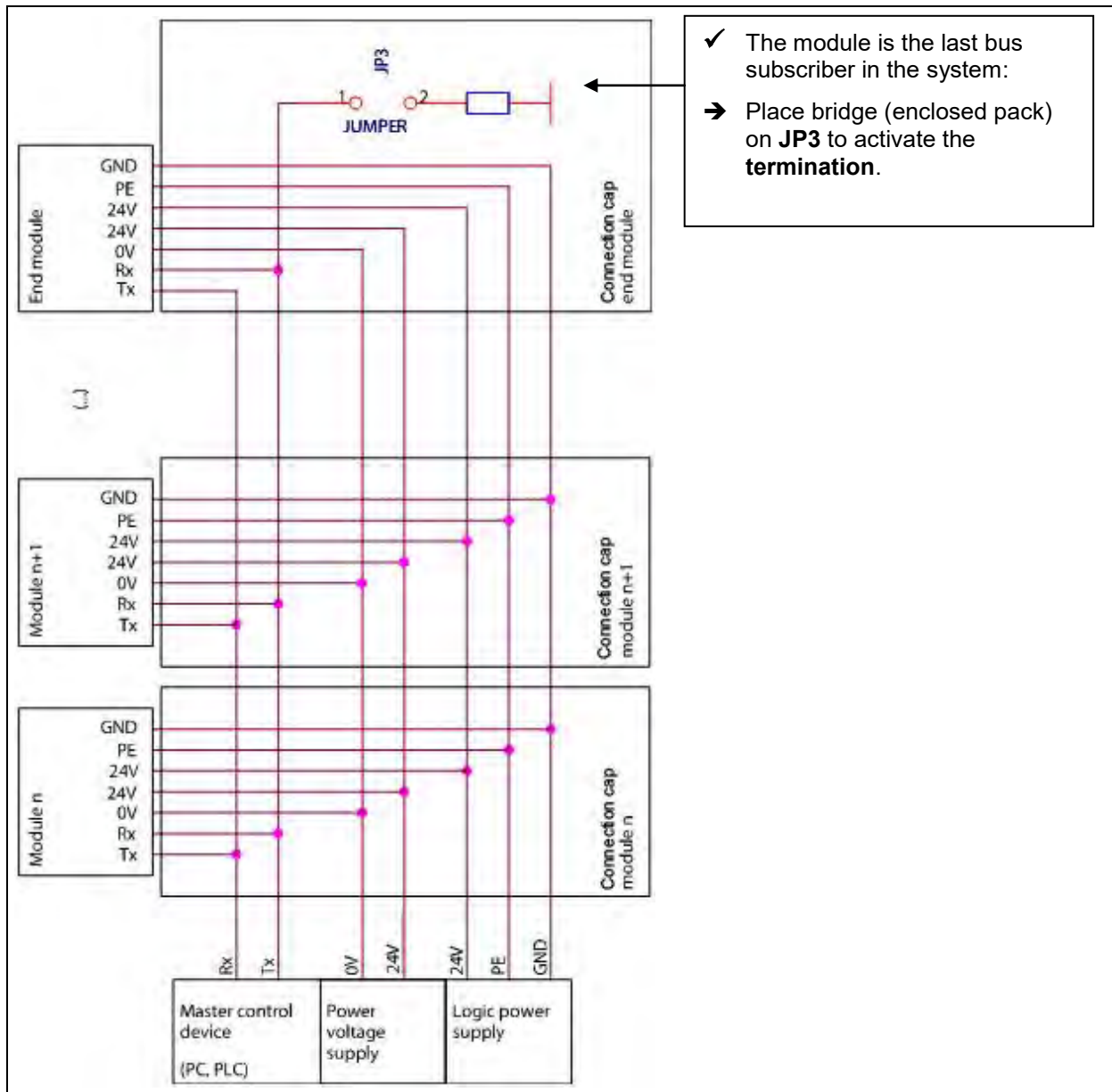

Figure 11 RS232 circuit diagram

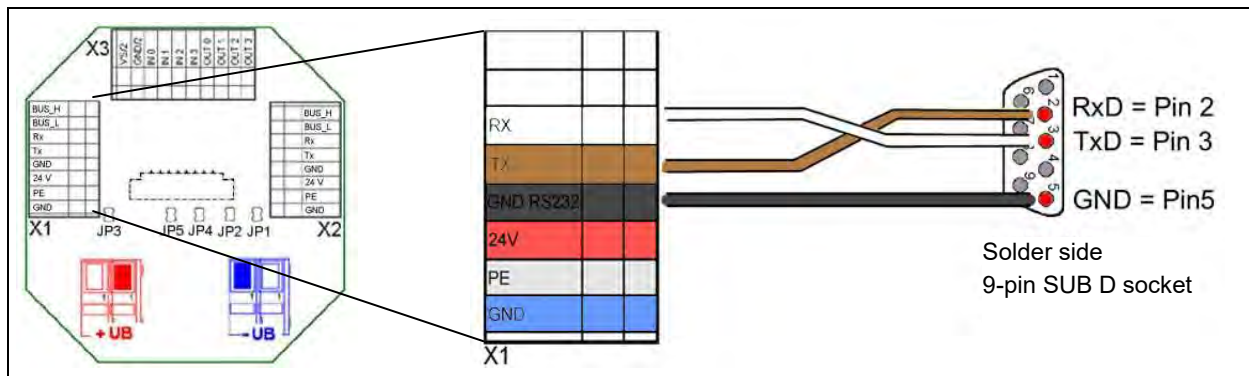

Figure 12 Connection board: Terminal strip X1 and connection to 9-pin SUB D socket

Connection	Terminal	SCHUNK cable color	
RS232 interface	Tx	brown	
	Rx	white	
	GND (Rx/Tx)	black (from Rx/Tx)	
Logic connection	24V	red	0,25 mm <sup>2</sup>
	GND	blue	0,25 mm <sup>2</sup>
Output power supply	+UB	blue	2,5 mm <sup>2</sup>
	-UB	red	2,5 mm <sup>2</sup>

Table 11 RS232 connection: Assignment of terminal strip X1

### Combining several modules

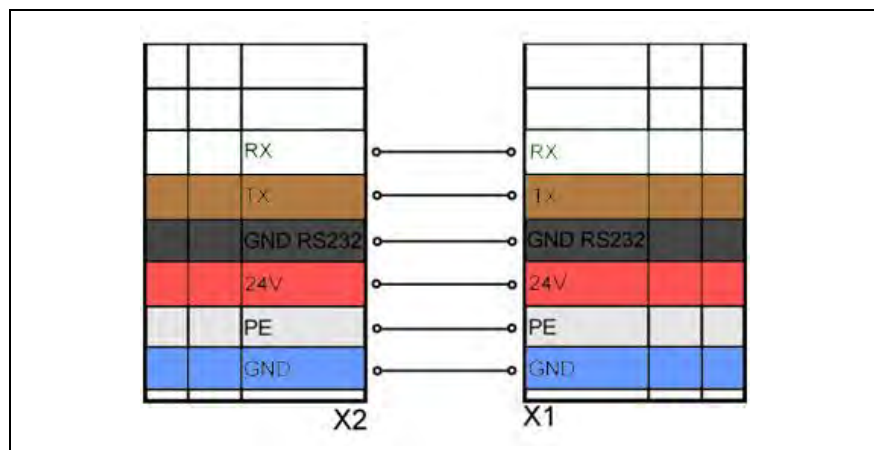

Figure 13 Combining module n with module n+1

When combining several modules, the signals from module n are looped through to module n+1. The wires from terminal X2 on module n are connected to terminal X1 on module n+1.

**8.3.3 CAN interface**

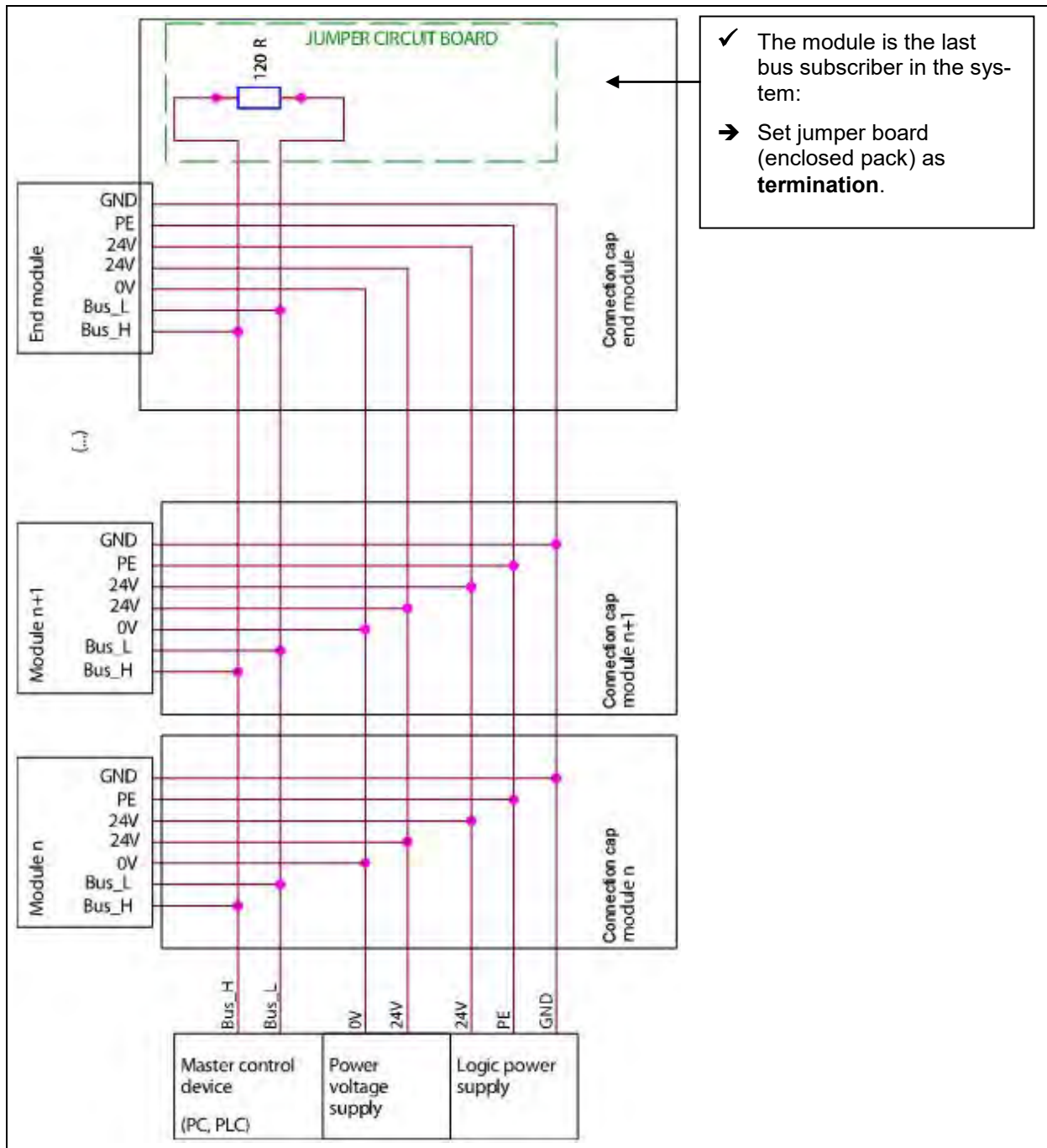

Figure 14 CAN circuit diagram

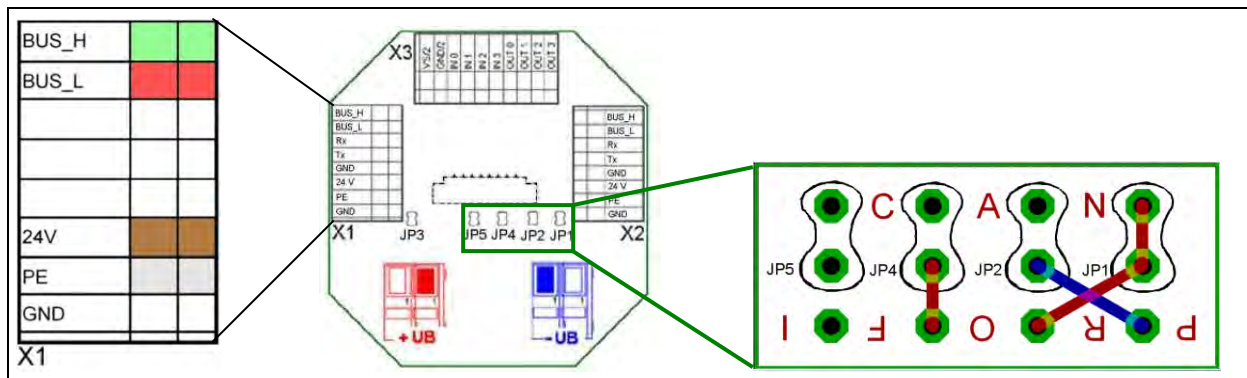

Figure 15 Connection board: Terminal strip X1 and jumper board for termination

Until 2010-12

Anschluss	Klemme	SCHUNK Kabelfarbe	
CAN interface	Bus_H	yellow	
	Bus_L	green	
	PE	shield	
Logic connection	24V	brown	0,25 mm <sup>2</sup>
	GND	white	0,25 mm <sup>2</sup>
Logic connection	+UB	red	2,5 mm <sup>2</sup>
Output power supply	-UB	blue	2,5 mm <sup>2</sup>

Tab. 12 CAN connection Assignment of terminal strip X1

From 2011-01

Anschluss	Klemme	SCHUNK Kabelfarbe	
CAN interface	Bus_H	white	
	Bus_L	red	
	PE	shield	
Logic connection	24V	red	0,25 mm <sup>2</sup>
	GND	blue	0,25 mm <sup>2</sup>
Output power supply	+UB	red	2,5 mm <sup>2</sup>
	-UB	blue	2,5 mm <sup>2</sup>

Tab. 13 CAN connection Assignment of terminal strip X1

SUB D socket solder side	Pin	Terminal
	2	Bus_L
	7	Bus_H

Table 14 CAN assignment of 9-pin SUB D socket

**Combining several modules**

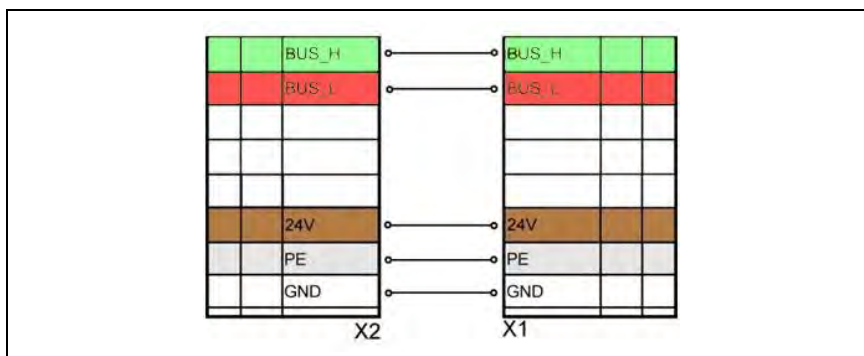

*Figure 16 Combining module n with module n+1*

When combining several modules, the signals from module n are looped through to module n+1. The wires from terminal X2 on module n are connected to terminal X1 on module n+1.

### 8.3.4 Interface Profibus DP

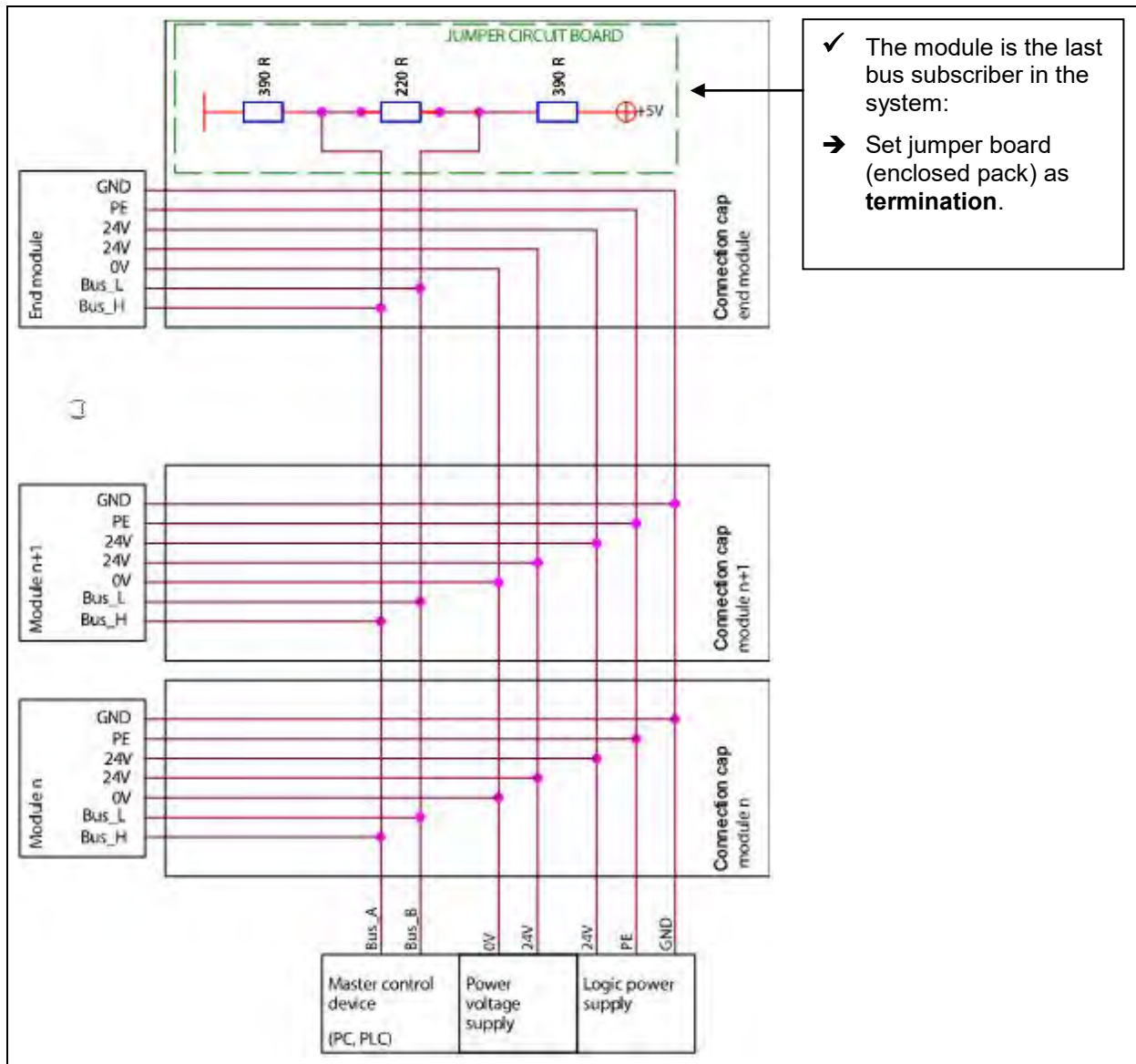

Figure 17 Profibus DP circuit diagram



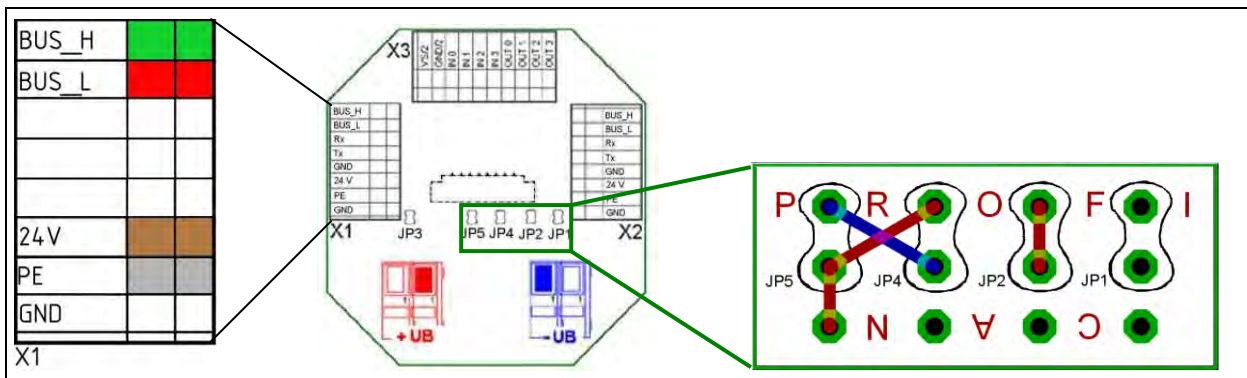

Figure 18 Connection board: Terminal strip X1 and jumper board for termination

Connection	Terminal	SCHUNK cable color	
Profibus DP interface (cable 1)	Bus_H (Bus_A)	green	
	Bus_L (Bus_B)	red	
	PE	shield (from cable 1 & 2)	
Logic connection (cable 2)	24V	brown	0,25 mm <sup>2</sup>
	GND	white	0,25 mm <sup>2</sup>
Output power supply	+UB	red	2,5 mm <sup>2</sup>
	-UB	blue	2,5 mm <sup>2</sup>

Table 15 Profibus DP connection Assignment of terminal strip X1

SUB D socket solder side	Pin	Terminal X1
	3	Bus_L (Bus_B)
	8	Bus_H (Bus_A)

Table 16 Profibus DP assignment of 9-pin SUB D connector

### Combining several modules

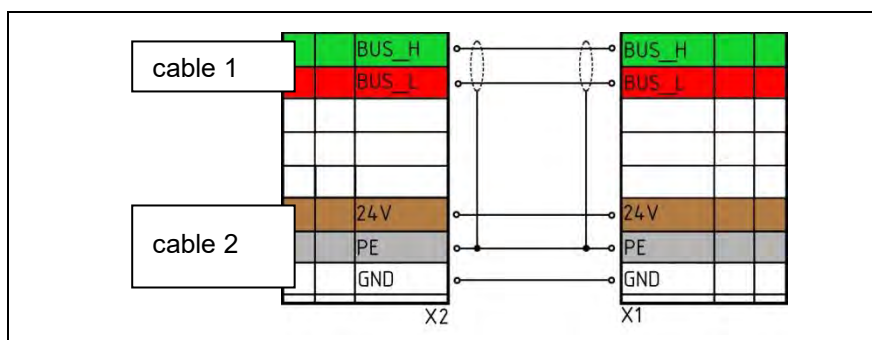

Figure 19 Combining module n with module n+1

When combining several modules, the signals from module n are looped through to module n+1. The wires from terminal X2 on module n are connected to terminal X1 on module n+1.

### 8.3.5 Electrical connection of the terminal strip X3

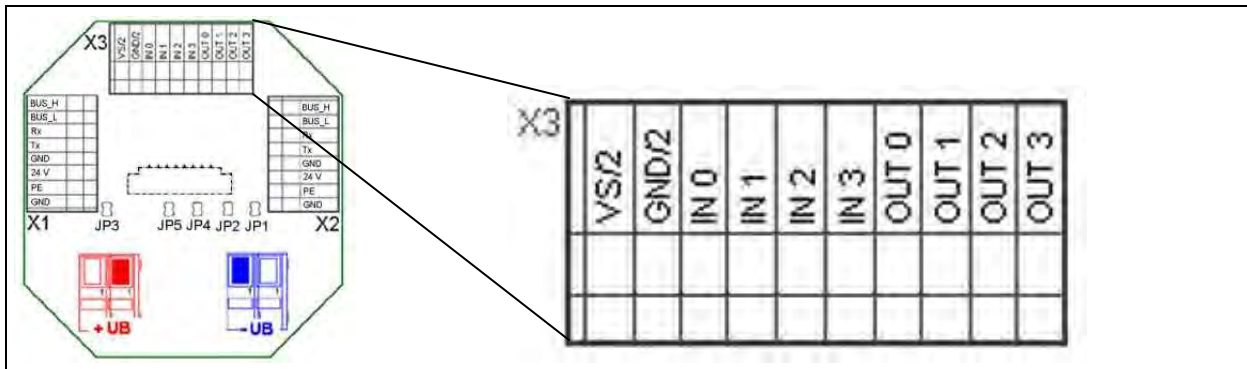

Figure 20 Connection board: terminal strip X3

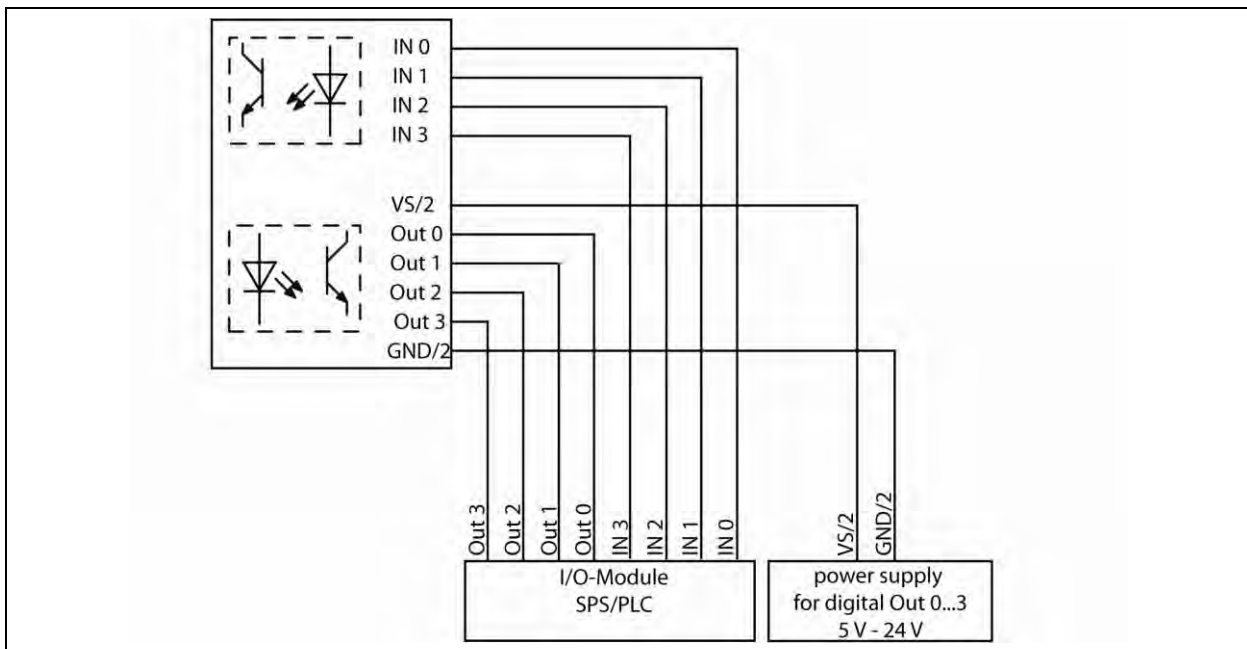

Figure 21 Circuit diagram for digital inputs and outputs



**Assignment of terminal strip X3**

Description	Application: Program	Application: Normal
IN0	Release / External reference switch (as of Firmware 1.20)	Digital input
IN1	Sentence selection	Digital input
IN2	Sentence selection	Digital input
IN3	Sentence selection	Digital input
OUT0	Reference (low active)	Digital output
OUT1	Error message (low active)	Digital output
OUT2	Depending on the configuration (low active) - see Table 18	Digital output
OUT3	Movement finished (low active)	Digital output

*Table 17 In- and outputs*

Set-up	Description
Normal	Digital output via CMD_DIO switchable
Status + movement	OUT2 reports, if the module is moving.
Status + position achieved	OUT2 reports, if the module achieved a position.
Status + brake	OUT2 reports the condition of the brake.
Status + warning	OUT2 reports, if a warning is pending.
Status + program run	OUT2 indicates, if the module is situated in a program run.

*Table 18 Switching possibilities of the output OUT2 via Motion Tool Schunk  
(as of Firmware V1.22)*
**Notes**

Further information and usage options for terminal strip X3 can be found in the "MTS" configuration tool (see DVD, Document: MotionControl.pdf).

### 8.3.6 DEFAULT and BOOT function

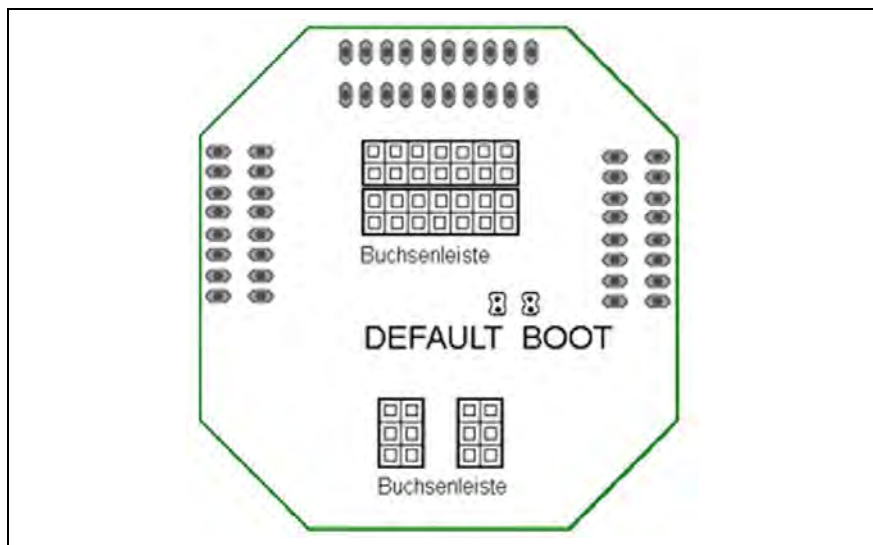

Figure 22 Connection board: Rear

#### Setting the module to factory settings

The module can be reset to the factory settings using the DEFAULT function:

1. Turn off the power supply.
2. Unscrew the four screws (M4 x 35mm) for the connection cap using a hexagon socket wrench (size 3).
3. Detach the connection cap from the module.
4. Place the jumper (enclosed pack) at the DEFAULT connector on the connection board.
5. Reconnect the connection cap to the module.
6. Turn on the power supply for around 10 seconds.
7. Turn off the power supply and detach the connection cap from the module.
8. Disconnect the jumper from the DEFAULT connector.
9. Reconnect the connection cap to the module.
10. Tighten the connection cap screws uniformly.

The module is now set to the DEFAULT values (see chapter 6.2, page 14).

**Loading new  
firmware to the  
module****Applicable for firmware 1.3.x till 15.04.2010:**

New firmware can be loaded to the module using the BOOT function:

- ✓ RS232 communication interface is connected and active. (see chapter 8.3.2, page 25)
- 1. Turn off the power supply.
- 2. Unscrew the four screws (M4 x 35mm) for the connection cap using a hexagon socket wrench (size 3).
- 3. Detach the connection cap from the module.
- 4. Place the jumper (enclosed pack) at the BOOT connector on the connection board.
- 5. Reconnect the connection cap to the module.
- 6. Turn on the power supply again.
- 7. The module is in BOOT mode. New firmware is transferred to the module using the MTS tool (see MotionControl.pdf)
- 8. Turn off the power supply.
- 9. Detach the connection cap from the module.
- 10. Disconnect the jumper from the BOOT connector.
- 11. Reconnect the connection cap to the module.
- 12. Tighten the connection cap screws uniformly.

**Notes**

For further information, refer to the MotionControl.pdf document on the DVD supplied.

**Applicable for firmware 1.4.x from 16.04.2010:**

Module can be overwritten with a new firmware by the function „Modul“ – „Firmware update“ of the software MTS (included on the provided CD).

**Note**

Versions of software and firmware need to be adapted to each other.

## 8.4 System integration

### 8.4.1 System structure

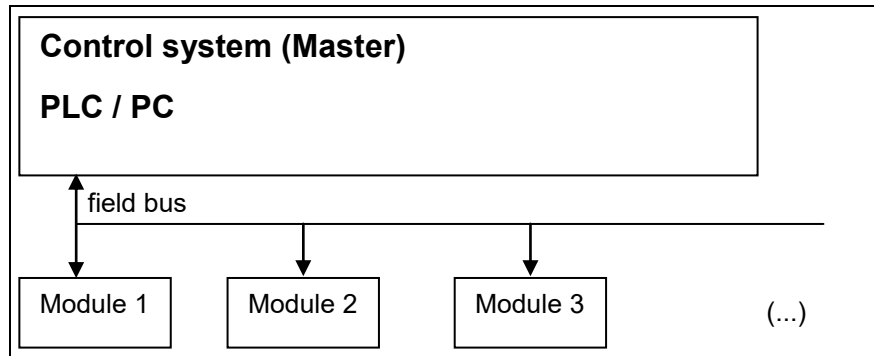

Figure 23

#### Data format

The data is transferred in INTEL Format (Little Endian Format).

#### Notes

The number of modules connected depends on the bus used. A maximum of 255 IDs can be assigned (see DVD, Document: MotionControl.pdf).

### 8.4.2 SCHUNK Motion protocol

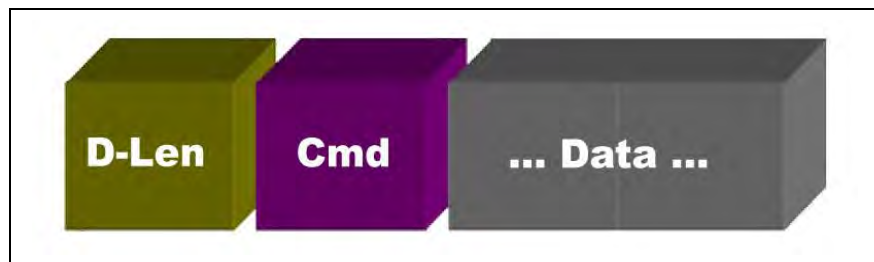

Figure 24

The data frame of the Motion protocol always includes the following elements:

- D-Len (1-byte)
- Command Code (1 byte)

D-Len (Data Length) specifies the number of subsequent items of user data including the command byte. The data frame consists of one byte, therefore a Motion protocol message can transfer a maximum of 255 data bytes.

The D-Len byte is always followed by the command code, consisting of one byte. If necessary, the command code is followed by the relevant parameters required. If required, a "master command" can be extended with a "sub-command".

All commands sent are immediately confirmed by the module with a response (acknowledge). This response also uses the data frame described above (D-Len, command code, any parameters). If the request has been successfully processed, D-Len always has a value that is not equal to "0x02". If the request failed, D-Len has the value "0x02".

**Notes**

The special features of the different bus systems are described in MotionControl.pdf (see DVD, Document: MotionControl.pdf).

**8.4.3 Most important commands**** DANGER**

**Risk of injury when the machine/system moves unexpectedly due to incorrect programming!**

→ Only specialist personnel or specially trained staff should carry out settings and enter parameters.

**Notes**

In all examples, only the necessary parameters are listed, not the optional parameters. In the examples, "M" stands for master and "S" for slave (= module).

**Referencing**

**Command Code:** 0x92

**Description:** A referencing is executed.

Parameters (Master ⇨ Slave): None.

**Response** (Slave ⇨ Master): "OK" (0x4F4B) if successful.  
The module executes the command.

**Miscellaneous:** Spontaneous response possible.

	D-Len	Cmd	Param	Meaning
M ⇨ S	0x01	0x92		
S ⇨ M	0x03	0x92	0x4F 0x4B	Successfully referenced

Table 19 Example for REFERENCE

**Positioning**

**Command Code:** 0xB0

**Description:** Moves the module to a specified position.

**Parameters** (Master ⇨ Slave):

- Position in configured unit system (must be specified)
- Velocity (optional)
- Acceleration (optional)
- Current (optional)
- Jerk (optional)

**Response** (Slave ⇨ Master): If possible, the time that the module needs for the movement is returned.

**Miscellaneous:** Spontaneous response when position reached or in case of prior termination of positioning.

	D-Len	Cmd	Param	Meaning
M ⇨ S	0x05	0xB0	0x00 0x00 0x20 0x41	Move to position 10.0[mm]
S ⇨ M	0x05	0xB0	0xCD 0xCC 0x04 0x41	Will reach position in 8.3[sec]

Table 20 Example for MOVE POS

**Current move**

**Command Code:** 0xB3

**Description:** A current move is executed.

**Parameters** (Master ⇌ Slave):

Current in configured unit system (must be specified).

**Response** (Slave ⇌ Master): "OK" (0x4F4B) if successful.  
The module executes the command.

**Miscellaneous:** Spontaneous message is possible.

	D-Len	Cmd	Param	Meaning
M ⇌ S	0x05	0xB3	0x00 0x00 0x60 0x40	Execute current move with 3.5[A]
S ⇌ M	0x05	0xB3	0x4F 0x4B	

Table 21 Example for MOVE CUR

**Velocity move**

**Command Code:** 0xB5

**Description:** A velocity move is executed.

**Parameters** (Master ⇌ Slave):

- Velocity in configured unit system (must be specified)
- Current (optional)

**Response** (Slave ⇌ Master): "OK" (0x4F4B) if successful.  
The module executes the command.

**Miscellaneous:** Spontaneous message is possible if the module is no longer moving.

	D-Len	Cmd	Param	Meaning
M ⇌ S	0x05	0xB5	0x9A 0x99 0x31 0x41	Execute velocity move with 11.1[mm/s]
S ⇌ M	0x05	0xB5	0x4F 0x4B	

Table 22 Example for MOVE VEL

**Stop module**

**Command Code:** 0x91

**Description:** The module is braked and stopped in the current position.

**Parameters** (Master ⇌ Slave): None.

**Response** (Slave ⇌ Master): "OK" (0x4F4B) if successful.

**Miscellaneous:** Spontaneous message is possible.

	D-Len	Cmd	Param	Meaning
M ⇌ S	0x01	0x91		
S ⇌ M	0x03	0xB5	0x4F 0x4B	OK

Table 23 Example for CMD STOP

**Emergency stop**

**Command Code:** 0x90

**Description:** The module is stopped as quickly as possible. If a brake is fitted and appropriately configured, it is activated immediately. The motor phases are short circuited.

**Parameters** (Master ⇌ Slave): None.

**Response** (Slave ⇌ Master): Error message "ERROR FAST STOP" is triggered.

**Miscellaneous:** Can only be reset by "CMD ACK".

	D-Len	Cmd	Param	Meaning
M ⇌ S	0x01	0x90		
S ⇌ M	0x03	0x88	0xD9	fast stop executed

Table 24 Example for CMD FAST STOP



**Acknowledge error**

**Command Code:** 0x8B

**Description:** Acknowledgement of an error message.

**Parameters** (Master ⇌ Slave): None.

**Response** (Slave ⇌ Master): "OK" (0x4F4B)

**Miscellaneous:** When all errors have been successfully acknowledged, after sending "OK" (0x4F4B), an info message "INFO NO ERROR" is also sent.

	D-Len	Cmd	Param	Meaning
M ⇌ S	0x01	0x8B		
S ⇌ M	0x03	0x8B	0x4F 0x4B	OK

*Table 25 Example for CMD ACK*

**Notes**

For further information, refer to the MotionControl.pdf document on the DVD supplied.

## 9 Troubleshooting

### 9.1 Module does not move

Possible causes	Remedial measures
Communication with the module is not possible	→ Check bus connection (see chapter 8.3, page 21)

Table 26

### 9.2 The module is sluggish or jerky

Possible causes	Remedial measures
Dirt deposits in the cavities	→ Clean the module (see chapter 10.1, Page 44)

Table 27

### 9.3 The module's motor is not turning

Possible causes	Remedial measures
No voltage connected	→ Check the power supply
Insufficient voltage	→ Check the power supply requirements (see chapter 6.3, Page 15)

Table 28

### 9.4 Module stops abruptly

(This can be reported by the module using the **ERROR\_CABLE\_BREAK (0x76)** parameter if the GSD file supplied has been integrated.)

Possible causes	Remedial measures
Bus cable fault (connection to module broken)	→ Check bus cable for damage and replace if necessary. → For more troubleshooting, see MotionControl.pdf.

Table 29

### 9.5 Motor turns but module does not move

Possible causes	Remedial measures
Fingers are mechanically jammed	<ul style="list-style-type: none"> <li>➔ Check the levelness of the bolting surface. (see chapter 8.1, Page 19)</li> <li>➔ Check whether the adapter plate is displaced (only in case of side mounting).</li> </ul>

Table 30

### 9.6 The gripper does not execute the full stroke

Possible causes	Remedial measures
Dirt deposits between the cover plate and chuck piston	➔ Clean gripper and re-lubricate, if necessary.
Dirt deposits between the base jaws and the guide	➔ Clean gripper and re-lubricate, if necessary

Table 31

### 9.7 The gripping force drops

Possible causes	Remedial measures
Dirt deposits in the cavities	➔ Clean the module (see chapter 10.1, Page 44)
Dry-running of the spindle	➔ Re-lubricate module (see chapter 10, page 44)

Table 32

### 9.8 The gripper opens or closes abruptly

Possible causes	Remedial measures
Dirt deposits in the cavities	➔ Clean the module (see chapter 10.1, Page 44)
Dry-running of the spindle	➔ Re-lubricate module (see chapter 10, page 44)

Table 33

## 10 Maintenance and care

### 10.1 Maintenance intervals

**⚠ WARNING**

**Risk of injury when the machine/system moves unexpectedly!**

➔ Switch off energy supply.

Type	70
Interval [Mio. cycles]	2
einen kompletten Hub fahren [Zyklen]	1.000

Table 34

The module complies with protection class IP 54 with mounted connection cap DMI.

- ➔ Clean the module dry, remove all coarse dirt and chips from the cavities on the module.
- ➔ Check for damage and replace the module if necessary.

Any repair work on the module may only be carried out by SCHUNK.

- ➔ Call the service hotline or your SCHUNK contact.
- ➔ Send the module to SCHUNK with a repair request.

### 10.2 Lubricants/Lubrication points (basic lubrication)

We recommend the lubricants listed. Provably equivalent lubricants can also be used.

- ➔ During maintenance, treat all grease areas with lubricant.

Lubrication points	Lubricant
meta sliding surface	KP2-K or CLP32-100 (Details see Table 36)

Table 35

Details	Lubrication grease	Lubrication oil
DIN	KP2-K	CLP32-100
DIN No.	51502 / 51825	51517 part 3
Note	Soap grease	ISO VG 32-100

Table 36

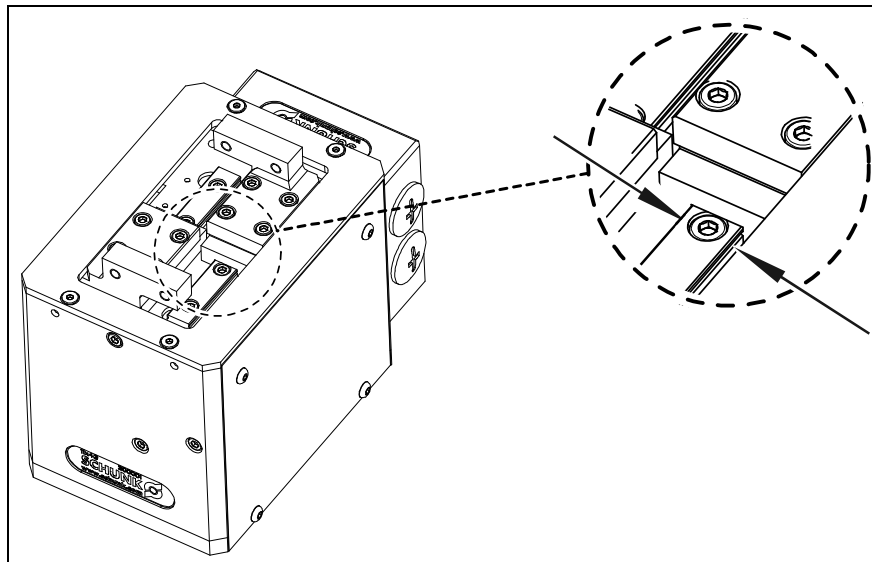

Figure 25 Lubrication points

1. Apply lubricant to the lubrication points.  
(see Figure 25)
2. Disperse lubricant:  
Execute two to three times the complete stroke.

### 10.3 Dismantling the module

The module may only be dismantled by SCHUNK as otherwise the mechanism or internal electronics may be damaged.



## 11 Translation of original EC declaration of incorporation

In terms of the EC Machinery Directive 2006/42/EC, annex II B

Manufacturer/  
distributor                      SCHUNK GmbH & Co. KG.  
    Spann- und Greiftechnik  
    Bahnhofstr. 106 – 134  
    D-74348 Lauffen/Neckar

We hereby declare that the following product:

**Product designation:**    Servo Electric 2-Finger-Parallel Gripper  
**Type designation:**        PG 70  
**ID number:**                 0306 095

meets the applicable basic requirements of the Directive Machinery (2006/42/EC).

The incomplete machine may not be put into operation until conformity of the machine into which the incomplete machine is to be installed with the provisions of the Machinery Directive (2006/42/EC) is confirmed.

Applied harmonized standards, especially:

EN ISO 12100-1        Safety of machines - Basic concepts, general principles for design -- Part 1: Basic terminology, methodology  
EN ISO 12100-2        Safety of machines - Basic concepts, general principles for design -- Part 2: Technical principles

The manufacturer agrees to forward on demand the special technical documents for the incomplete machine to state offices.

The special technical documents according to Annex VII, Part B, belonging to the incomplete machine have been created.

Person responsible for documentation:

Mr. Uwe Heinz. Address: see manufacturers address

Location, date/signature:    Lauffen, January 2012    ppa. 

---

Title of the signatory

Director for Development

---

